

A-A  
SCALE: 1 : 2

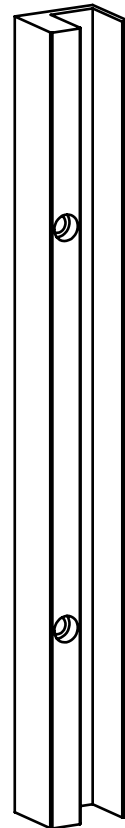
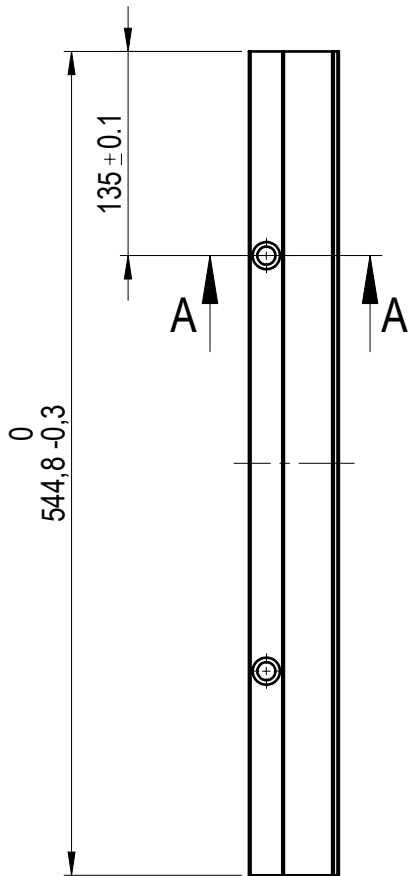
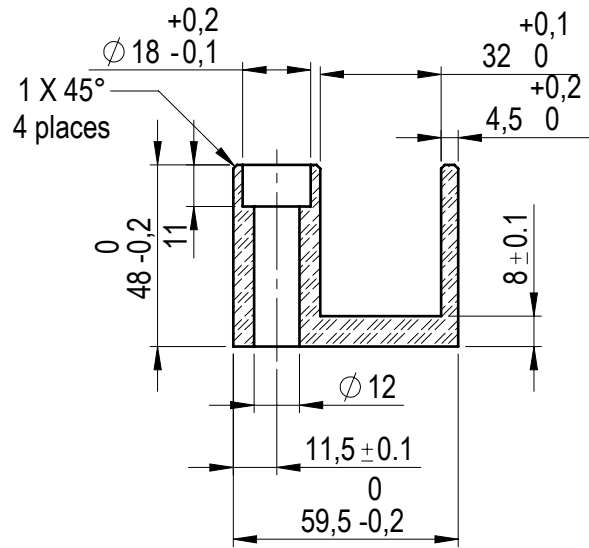

Other dimensions from .STEP file

	MATERIAL		WEIGHT	DEBURR AND BREAK SHARP EDGES		REVISION	DATE	
	6082 T6		2.277 Kg	DO NOT SCALE DRAWING			04.04.2025	
SURFACE PROTECTION		MACHINING	THERMAL CUTTING	WELDING		SCALE	FORMAT	
Anodizing ISO 7599:2010		ISO 2768 mK	ISO 9013 441	ISO 13920 BF		1:5	A4	
NAME		SIGNATURE	PART NO.					
Designed by	D. Dislers		105-11203-02					
Drawn by	D. Dislers		DESCRIPTION				SHEET 1/1	
Technical ref.			Glass bracket A3					